

INDIAN BANK

TENDER DOCUMENT
FOR
INTERIOR, FURNISHING, ELECTRICAL
and
AIR CONDITIONING WORKS
AT
INDIAN BANK'S

**BRANCH & E-LOBBY AT PRECIOUS MALL,
MOTI DOONGRI ROAD, JAIPUR**

Office of the
Deputy General Manager
Indian Bank, Zonal office Jaipur
S.F.-50, JTM MALL,
Near Jagatpura Flyover, Model Town
Malviya Nagar
Jaipur - 302017
Ph:0141-2360552

ARCHITECTS:
NARENDER CONSULTANTS
2/87 NIRANKARI COLONY,
DELHI-110009
PHONE: - +91-11-27659642
MOBILE: +91-9810039762
EMAIL: astrologernarender@yahoo.com

LAST DATE & TIME OF SUBMITTING TENDERS: 20-01-2017 UPTO 1.00 P.M.
DATE & TIME OF OPENING OF TENDER: SAME DAY i.e. 20-01-2017 AT 2.30 P.M.

Name of the Contractor :.....

DETAILS OF TENDER

TENDER FOR THE FURNISHING/ELECTRICAL/AIR CONDITIONING OF INDIAN BANK'S BRANCH & E-LOBBY AT PRECIOUS MALL, MOTI DOONGRI ROAD, JAIPUR

1. Details of work to be done : Interior/Furnishing, electrical and Air conditioning works of Indian Bank's Branch & E-Lobby at Precious Mall, Moti Doongri Road, Jaipur
2. Form of contract : Item wise rate
3. Earnest Money : Rs. 15,000/- (Fifteen Thousand only) in form of Demand draft in favour of Indian Bank, payable at Jaipur
4. sPeriod of contract/
time of Completion : 4 weeks
4. Last date & time for receiving
of sealed tender : 20-01-2017 UPTO 1.00 P.M.
5. Liquidated damages for non
completion of work in time : 1.0% of the contract value per week
subject to a max of 10% contract
value.
7. Defect Liability period : 12 months (Twelve months) from the
date of virtual completion as
certified by Architect/employer.
8. Retention amount for 12 months: 8% of the total bill (This will include the earnest
money already deposited
9. Period of submitting of
Final bill. : 10 days from the date of completion.
10. Mobilization Advance/
Secured Advance : No. Mobilization Advance/secured
Advance will be given to the
Contractor.
11. Place and date of opening : 20-01-2017 AT 2:30 P.M. in the office of the DGM,
S.F.-50, J.T.M. Mall, Near Jagatpura Flyover, Model town,
Malviya Nagar, Jaipur-302001

GENERAL CONDITIONS

1. The contractor shall sign each page of this tender.
2. Payment to the contractor Agency shall be made as per actual work done of site.
3. Quantity of work may increase or decrease of the site as per requirement, which shall not affect the rates quoted by the contractor.
4. Furnishing works including electrical works etc. shall be done to the complete satisfaction of Bank and architect-in-charge.
5. All teak/cedar wood/rubber wood to be used should be knotless which is to be polished with all background surface preparation course maintaining the visibility of wood grains.
6. The rates to be quoted shall include the transportation, VAT or all other applicable taxes and nothing extra would be paid on whatsoever ground.
7. The contractor agency shall keep particular vigil on his workers/carpenters/ painters etc. to maintain very good workmanship of all items, failing which no payment shall be made and no claim of material/labour used shall be made to him in any case, and the same work shall be executed by him again without charging any extra cost.
8. The rates should be written both in words and figures without any erasers and alterations. However, if errors are made, the wrong figures or words must be neatly scored out under full signature of the tenderer and the correct figures and words neatly rewritten. Over writing is not permitted. White fluid should never be used for corrections.
9. In the event of an error occurring in the amount columns as a result of wrong multiplication and extension of unit rate and quantities, the unit rate shall be regarded as firm and the amount shall be amended accordingly.
10. Any tender / quotation containing clerical or arithmetical mistakes shall be amended as per actual.
11. Any addition, alteration or correction shall be signed and stamped properly.
12. All items to be executed as per drawing, if any change is required, the same shall be brought to the notice of architect-in-charge.
13. Incomplete tenders/quotations will be rejected.
14. Any addition, alteration or correction in the tender shall be signed and stamped properly by the contractor.
15. Contractor agencies are advised (before quoting the rates) to inspect the site of the proposed work. He must go through all drawings and specifications and documents. Any clarification, if required, may be taken from the Architect before the start of the work.
16. The Bank reserves the right to accept/reject any tender/quotation without assigning any reasons.

17. Any work got executed in poor workmanship as pointed out by the Architect/Bank's Official will have to be dismantled and redone by the Contractor on his own cost.
18. No advance payment shall be made to the contractor on supply of any material supplied at site for execution, payment shall only be made on execution of any concerned/particulars item.
19. The rates shall include the cost of coat of anti termite treatment on wooden frame, commercial ply, boards and other materials being used in work.
20. Rates for partitions, paneling, wall cladding and false ceiling shall include cutting and making good necessary cut-outs/chiseling to be made for electrical conduits, switch boards etc.
21. Bank shall not be responsible for any lose or damage to the contractor/labour due to any natural calamity during the course of construction. Contractor is liable to make good all the damages if any, till the work is completed and handed over to the Bank authorities.
22. Any payment to the contractor on account of execution of work, whether it is running payment of final, shall be verified by the architect-incharge.
23. The work has to be completed within the stipulated time of completion. In the event of delay, relevant penalty clause will be invoked. However, if the work is delayed due to the reasons beyond the control of the contractor, he should keep intimating the Bank explaining, therein the reasons for such delays, immediately and if in the opinion Bank's authorities the delay is justified, the contractor shall be granted extension in time limit.
24. Bank may award the work in part or whole to a single party or any other party.
25. It may please be noted that the bank is not bound to allot the work to the lowest party. And as such, the allotment of work shall be based on workability of rates quoted by the contractor on account of quality.
26. The bank reserves the right to reject any or all the tender without assigning any reason whatsoever.
27. The earnest money deposited shall not carry any interest and will be refunded to the unsuccessful tenders.
28. Earnest money paid by the contractor shall be forfeited by the bank if contractor fails to undertake the job if he is communicated about acceptance his rates/tender.
29. All the rates quoted are inclusive of removal of existing counter, partitions, and wiring. Rubbish /debris collected during the progress of work, rejected materials etc.
30. The contractor shall not directly or indirectly sublet the work to other party without written permission of the bank.
31. The quantities mentioned in schedule are provisional and likely to increase /decrease to any extent or may be omitted thus altering the aggregate value of the contract. No claim for loss of profit/business shall be entertained on this account.
32. Entire work has to be done in Bank's approved colour scheme, design and pattern.

33. The Bank reserves the right to distribute the work for which quotations have been called, among more than one parties, if found necessary. No claim in this respect shall be considered and the contractor agrees to cooperate with other agencies appointed by the Bank.
34. All the workers of the contractor must be properly covered by an insurance policy under “Workman’s compensation act” and “Fatal accidents Act”. The contractor of his own expenses arrange to effect and maintain until the virtual completion of the contract, insurance policy in the joint name of Bank and the contractor against his risk to be retained by the Bank until the virtual completion of the work, and indemnify the Bank from all the liabilities arising out of such events. In case delay, contractor shall arrange to extend insurance policy till work is completed.
35. The contractor shall furnish well in time before work commence of his own cost, colour samples, samples of materials of workmanship that may be called by Bank’s Architect/engineer for approval. Rates quoted shall cover for such preliminary work.
36. All the glass panes, door handles/hinges, electric fittings, fans, furniture, records, floors etc. are to be thoroughly cleaned offer the work is completed.
37. The rates quoted by the contractors shall be firm throughout the duration of contract (including extension of time if any granted) and will not be subject to any fluctuation due to variation-in cost of material and labour.
38. Conditional tenders are liable to be rejected.
39. The successful tenderer is bound to carry out any item of work necessary for the completion of the job even those such items are not included in schedule of quantities.
40. If in any case of work required to be abandoned, the contractor shall not be entitled for any claims and he will be paid as per the actual work done till that period. If deemed fit.
41. Decision of the Bank shall be final and binding on any matter connected with the work. The matter of any dispute shall be decided after mutual discussions based on the terms and conditions of the contract. However, if the matter cannot be resolved there the same shall be referred to the respected qualified persons in agreed to both the parties and his opinion shall be binding on both the parties. However, this is recourse of any legal action in this regard.
42. If any stage during the progress of work, it is observed that the contractor is not progressing the work with due diligence, care of lagging much behind the schedule of fails go get up the work despite instructions from Bank’s architect, the Employer (Bank) reserves the right to terminate the contract with 7 days notice. In such case the contractor shall be liable to pay the employer any extra cost involved for the completion of the said work and will not obstruct any way in completing the work through other agency. After completion of entire work the contractor shall be paid for the actual work executed by him at the quoted rates after deducting any claims, damages. In case of such termination the security deposit held by the bank will be forfeited.

43. Contractor shall follow all rules/regulations in force and should possess the license for employing labour and also follow all safety measures, labour bye laws and shall be responsible for any lapse.
44. At any stage i.e. during the execution of work, any kind of change reqd. whether it is in design or specification, the same has to be incorporated by the contractor.

CONTRACTOR

ARCHITECT

INDIAN BANK

List of Approved Makes/Brands for Material

INTERIOR FURNISHING ITEMS

S.No	Description	Material	1. Colour Scheme 2. Code No. 3. Name of Manufacturere
1	Flooring	Vitrified tiles 600 x 600 mm size	1. Camel Brown (Preferably light shade) 2. Johnson, Bell NITCO orequivalent
2	False Ceiling- Banking Hall	12mm thick Gypsum Board & 12mm thick Mineral fibre tile	1. White 2. India Gypsum & Armstrong, Gyproc, USG Ceiling or equivalent
3	False Ceiling- Cabins	12mm thick Mineral Fiber tile 600 x 600 mm	1.White 2. Armstrong , Gyproc,USC Ceiling or equivalent
4	Partitions	Frame work : Made of 50 x 50 mm hard word like sal wood/hillock or equivalent	
		Plywood :6mm thick commercial ply wood witj ISI certification	1..Archid ply, Duro Ply, Century Ply, Sharon Ply,Green ply or equivalent
		Laminates : 1.0mm thick laminate	1.Fusion Maple (wood finish) 2..Formica, Euro lam, Green lam, Merino or equivalent

5	Counter/tables	Plywood: 19mm /12mm/6mm thick commercial plywood with ISI certificate	1.Archid Ply, Duro Ply, Century, Sharon Ply, Green Ply, or equivalent
		Laminate: 1.5mm thick for table top and others 1.0mm thick laminate	1.Fusion Maple (wood finish) 2.Formica, Euro lam, Green lam, Merino or equivalent
6	Column Cladding	Laminate	1.Fusion Maple (wood finish) with regular skirting 2..Formica, Euro lam, Green lam, Merino or equivalent
7.	Wall Painting	Acrylic Emulsion	1. Sugar Cane 2. Asian Paints, Berger Paints, ICI, Nerolac or equivalent

List of Approved Makes/Brands for Material

ELECTRICAL MAKE OF MATERIALS

1	PVC fittings	Kalinga / AKG / Precision
2	Wires – PVC insulated copper	Finolex / Havells/ Kalinga
3	Cables (armored)	Gloster / Nicco / Havells / Evershine KDK
4	A.C Starter, Plug Socket	MDS / Crabtree / Northwest
5	Light & Power switch socket	Crabtree-Sapphire series /MK Modular Type/Anchor
6	Telephone Socket	RJ-11 Crabtree
7	DB MCB	MDS/ Havell's/MK
8	MCB	MDS G series / Havell's C series/MK
9	Telephone cable	.51 Netco / Delton / National
10	Light fitting	PHILIPS/Wipro/Crompton
11	Fuse Switch	L&T / Havell's
12	Ceiling/ Wall fan	Crompton / Orient / Khaitan
13	Exhaust fan	Crompton / Orient / Khaitan
14	Cable gland	Brass heavy type good quality
15	Distribution board	MDS / Havell's
16	MS conduit	Heavy duty with ISI mark 16 SWG
17	Starter & single phasing preventer	SEIMENS
18	SPN, TPN, Sheet metal	Havell's / MDS
19	Pipe Metal	M.S Conduit 16 S.W.G
20	Metal Pipe Fittings	Cast iron with thread & inspection cover
21	Pipe PVC (Rigid Conduit)	Kalinga / AKG / Precision

22	PVC fitting for Rigid	-Do-
23	PVC Roll Pipe	Super Dalda or equivalent heavy guage
24	PVC Casing & Casing Fittings	Good quality heavy guage (colour white)

List of Approved Makes/Brands for Material

Air Conditioning Works

S.No.	Item	Make
1	Indoor/Outdoor unit Carrier	Carrier /Hitachi/Blue Star/ DIAKIN/ VOLTAS (Copper coil)
2	AHUS	Carrier /Hitachi/Blue Star / DIAKIN (copper Coil)
3	Starters	L&T
4	Cables (power)	Finolex /power flex /RR-Kabel
5	Cables(control)	Finolex /power flex /RR-Kabel
5	Pipe PVC	Kalinga / AKG / Precision
6	Thermocole	Beardsell
7	Grills / Diffusers	Air Master / Air Breeze
8	Voltage Stabilizer	LOGICSTAT, MICEL, VOLTAS, EVEREST
9	Insulation Foam	PARAMOUNT, SUPREME
10	Copper Pipes	MET, DIAMOND
11	PVC Pipes	AKG/Precision

**ESTIMATE for INTERIOR, FURNISHING, ELECT. WORK IN INDIAN BANK
BRANCH AT PRECIOUS MALL. MOTI DOONGRI ROAD, JAIPUR**

GRAND SUMMARY

Sr. No.	DESCRIPTION	:	AMOUNT (Rs.)
A	SCHEDULE - 'A' (FURNISHING WORK)		
1.0	FALSE CEILING	:	
2.0	PARTITION WORK	:	
3.0	DOORS / WINDOWS	:	
4.0	WORKING COUNTER	:	
5.0	STORAGES	:	
6.0	ELECTRICAL WORK	:	
7.0	TELEPHONE WIRING	:	
	TOTAL SCHEDULE - 'A'		
B	SCHEDULE - 'B' (FURNITURE & FIXTURE)		
1.0	TABLES	:	
2.0	ELECTRICAL FITTINGS & FIXTURES	:	
3.0	MAIN BOARD , DB's	:	
	TOTAL SCHEDULE - 'B'		
C	SCHEDULE - 'c' (AIR CONDITIONING WORK)		
1.0	SPLIT AC UNITS	:	
2.0	PIPING CONDENCER & TIMER	:	
	TOTAL SCHEDULE - 'C'		
D	SCHEDULE - 'D' (SERVER ROOM INTERIOR WORK)		
I.	FURNISHING WORK	:	
II.	ELECTRICAL WORK		
1.0	ELECTRICAL WIRING	:	
2.0	CONDUITING & CABLING FOR DATA SYSTEM.	:	
3.0	CONDUITING & CABLING for U.P.S. SYSTEM	:	
4.0	LIGHT FIXTURE & FITTINGS	:	
III.	AIR-CONDITIONING WORK		
	TOTAL SCHEDULE - 'D'		
E	SCHEDULE - 'E' (ATM WORKS)		
1.0	INTERIOR WORK	:	
2.0	MISCLLANEOUS ITEMS	:	
3.0	WALL PANELING	:	
4.0	Electrical Installations	:	
	TOTAL SCHEDULE - 'E'		
F	SCHEDULE - 'F' (MISC. WORK)		
1.0	PIN UP / NOTICE BOARD	:	
2.0	BLINDS / CARPETS	:	
	TOTAL SCHEDULE - 'F'		
G	SCHEDULE - 'G' (PAINTING WORK)		
1.0	PAINTING WORK	:	
	TOTAL SCHEDULE - 'G'		
	TOTAL 'A + B + C + D + E + F + G'	:	
	less Discount(%) if any		
	TOTAL (after discount)		

**NOTE:- 1.Chairs are not included in the estimate.
2.Rolling shutter,collapsible gate & civil work is not included in the estimate.**

SCHEDULE OF QUANTITIES (SCHEDULE - A)

(Narender Consultants)

Sub: Furnishing/Electrical works in Indian Bank's Branch at PRECIOUS MALL, MOTI DOONGRI ROAD Z/O JAIPUR

S.No.	ITEM	QTY	UNIT	RATE (Rs.)	AMOUNT (Rs.)
1	<u>FALSE CEILING</u>				
1.1	P/F gypsum board false ceiling as per gypsum India manual i/c 2/3 coats of plastic paint over primer coat as per design. (The horizontal projection and vertical strips area of coves if provided will not be included and will be paid seperately in the item of coves)	432	Sq.Ft.		
1.2	P/F armstrong acoustical suspended ceiling system as per drawing with 15mm thick FISSURED tiles having tegular edges complete as per manufacturers specifications.	505	Sq.Ft.		
1.3	Providing/Making of L-shaped coves as per design at the junction of Armstrong and gypboard false ceiling including cost of vertical strips and horizontal projection and painting etc. complete.	76	Rft.		
2	<u>PARTITION WORKS</u>				
2.1	<u>FULL HEIGHT PARTITIONS</u> P/M.F. wooden Partitions Solid or Partly glazed all places including strong room, etc with 1mm laminate over 6mm thick commercial ply on both sides on 2"x2" Morentee wood frame work @ 2'-0" c/c bothways including 8mm thick clear glass ,frosted film as per design where required , (no deduction shall be made for glass) All grooves and design in straight line is inclusive in the rates. polish is also included in the rate.Moulding/Beeding for glass shall be in solid 1st classc.p.teak wood.The cost include providing & fixing of requisite doors including all fittings etc complete.	840	Sq.Ft.		
2.2	<u>LOW HEIGHT PARTITIONS 4'-0" ht</u>				
	Low height partly glazed partitions	110	Sq.Ft.		
2.3	<u>CASH CABIN PARTITION</u> as per Bank's approved design including door	53	Sq.Ft.		

3	<u>Aluminium Glazed Doors</u>				
3.1	P/F of Powder Coated Aluminium Glazed Doors/ Windows in approved colour with toughened glass as per design	104	Sq.Ft.		
3.2	P/F Floor Spring ISI approved	1	Nos.		
4	WORKING COUNTERS				
4.1	CASH CABIN COUNTER				
	<p>P/F Cash Cabin counter as per plan, having overall depth of 2' -6" wide 19mm comm. Block board all other places in between low height partitions. The customer top to be 1' -3" wide & 1'-2" clear above the table top. All vertical/exposed surfaces such as front of counter, drawer, counter top, etc are to be finished with 1.0mm th. laminate of approved shade. The item includes cost of customer top in laminated board / glass, polishing the counter & drawer units from inside with 2 or more coats of spirit/wax polish</p> <p>after preparing base pimer, putty etc. All teak surfaces to be spirit polished, complete with all hardware such as locks, handles, ball catchers, wire manager, hinges, as approved by the Architect complete as per details and drawings. The cashier counter shall also have drawer unit comprising of 3 No.s lockable drawers per unit per seat to put currency notes into it. (as per plan) The cost include footrest, sliding keyboard drawer, cable manager, computer trolley all EBCO make. Granite to be provided on transaction top.</p>	5	Rft		
4.2	COUNTER for passing officer/ clerk : shall have as above without transaction Top	14	Rft		
4.3	a) 1/2" thick toughened glass Fixed glazing in cash cabins and on other counters as required with SS fittings or wooden frame as required	50	Sq.Ft.		
5	STORAGES				

5.1	P/M/F wooden filing cabinets 1'-6" deep all heights including rear credenza behind officers' tables ,made out of ¾" thick commercial board as per design with facing of laminate on all front & seen surfaces. Cabinet to have back ply commercial fixed with nail & glue in side to be painted in white enamel colour in 3 coats to bring even surface and all front margins on edge to be polished in natural/ normal or any other shade as per given in drawing. The cost includes the cost of hinges ,lock & ball catcher, tower bolt etc complete in all respect. All accessories in stainless steel.	125	Sft		
5.2	Providing/making of enclosure in 19mm th commercial board for Electrical Panel, 1'-3" deep with louvers in front shutters (area of louvers should not be less than 50% of the shutters area) including all fittings etc complete. The item include the cost of lamination on all exterior surfaces, polishing of louvers and applying synthetic enamel paint on inner surfaces and fittings etc complete.	35	Sft		
6	ELECTRICAL WORK				
	SUB MAINS WIRING (including cost of PVC Conduit)				
6.1	From panel to AC DB : 4x 16Sq. MM + 1x 2.5 Sq.mm	5	Rmt		
6.2	From Panel to Light and Power DB : 4 x 6 Sq.mm + 1 x 2.5 sq. mm Cu Wire	5	Rmt		
	POINT WIRING i/c CIRCUIT WIRING				
6.3	Point wiring : Wiring for the following light/ wall fan, exhaust fan , call bell points with 1.5 sq.mm PVC insulated stranded Cu conductor wire in concealed/ exposed medium grade ISI marked PVC conduits as called for in specification including providing 1 sq.mm insulated Cu. earth wire including cost of circuit wiring from DB to the point with 2x2.5 sq.mm + 1x1.5 sq.mm complete with providing & fixing of accessories like saddles, clamps, flexible pipes , dash fasteners etc . Modular switches with face plates , switch boxes, grid plates are included in the above rates. The rate shall include cost of circuit wiring. Not more than 6 points in a circuit.				
(a)	1 Point controlled by 1 switch	32	nos.		

(b)	2 points controlled by 1 switch	25	nos.		
(c)	Wall mounted fan points with provision of 5 pin socket near the fan point.	13	nos.		
(d)	Wiring for sign board point using 2 x 2.5 Sq.mm Cu wire in PVC Conduit from Panel board to sign board	2	nos.		
	The above work includes extensions of points will flexible conduits as required to table bottoms etc as required.				
6.4	Wiring for 5 amp light plug point with 2x2.5+1x1.5 sq.mm PVC insulated Cu. Conductor wires in ISI marked PVC conduits including providing & fixing switch box, 5 amp socket, 5 amp switch complete of modular type (Maximum 6 points per circuit, circuit shall not be paid extra).	14	nos.		
6.5	Wiring of 15 amp power sockets with 2x4+1x1.5 sq.mm PVC insulated stranded Cu. Conductor wired in ISI marked PVC conduits including providing & fixing switch box, 5 amp socket , 5 amp switch complete of modular type (Maximum 2 points per circuit , circuit shall not be paid extra)	14	nos.		
6.6	(i) Wiring of AC points with 2x6+1x2.5 sq.mm PVC insulated stranded Cu. Conductor wires in ISI marked medium grade PVC conduits above ceiling including cost of conduits, wall chases complete as required including providing metal clad socket with SPMCB in sheet steel enclosure (one point per circuit, circuit shall not be paid extra).	5	nos.		
	(ii) Providing & fixing of Anchor Roma power socket near indoor units for supply to split type ACs	5	nos.		
22	Gen set wiring :-				
	(i) Supply laying fixing main power with 3.5 core 50 Sq.mm PVC insulated,PVC sheathed Alu.Conductor, 1100 v. grade armoured cable complete with 02 nos 8 SWG bear GI.wire as running earth.	30	Mts		

	(ii) End termination of 3.5 core 50 Sq.mm armoured cable, complete with brass cable gland , Alu. Lug, PVC tape.	1	End		
	TELEPHONE SYSTEM				
(i)	Wiring for telephone points with 2 pair 4/5 pair .51mm dia ATC (annealed tinned Cu wire) with PVC insulated PVC sheathed telephone cable from tag block to the point including providing ferrules at both ends and termination at both ends including providing & fixing RJ 11 outlet, faceplate and mounting box complete of modular type (where 2 such points are shown, 2 such wires shall be provided) This work includes providing PVC conduits in chases from the raceway to the point.	7	nos.		
(ii)	Supplying, laying, effecting terminations, testing and commissioning of 0.51mm dia Cu. Conductor, twisted , colour coded with polythene capor barrier, telephone cables in the existing tray or in conduit including providing & fixing conduit pipe or cable tray as required from building tag block to the floor as required.				
(a)	1x10 pair armoured cable from telephone connection in the premises to the crone box	20	Rmt		
b)	Supplying & fixing 20 pair krone tag block with enclosure.	1	nos.		
	TOTAL				

SCHEDULE OF QUANTITIES (SCHEDULE - B)

(Narender Consultants)

**Sub: Furniture & Fixtures in Indian Bank's Branch Office at Pecious Mall, Moti Doongri Road
Z/O JAIPUR**

S.No.	ITEM	QTY	UNIT	RATE (Rs.)	AMOUNT (Rs.)
1	TABLES AND SIDE RACKS (CREDANZAS)				
1.1	P/F/S. TABLES made out of ¾" thick commercial board with facing of laminate on all seen surfaces having foot rest in ¾" commercial board with painted all around. Polish to have on all margins and mouldings .One drawer & filing box shall have the M.P. locks.Shutter to have ¾"x3" medium quality s/s hinges & magnetic catcher .Provision to be made on table/counters of cable manager for cables . Readymade Key board and Cp.u. trolley of Ebco make.				
	(i) Table 5'-0" x 2'-6" (T1)	1	NO		
	(ii) Table 4'-6" x2'-0"(T2)	1	NO		
1.2	P/M/S side crednza made out of ¾" thick commercial board with facing of laminate 1mm thick in all seen surfaces having 2 openable flap & four drawers with all accessories and all drawers run on telescopic channels .All hardwares to be of s/s like ball catchers ,handles etc.				
	(i) S4 3'-0" x 1'-6" x 2'-6" (ht) (for Cash cabin)	1	Nos.		
	(ii) S3 : 3'-0" x 1'-3" x 2'-6" (ht)	2	Nos.		
	(iii) S1 : 3'-0" x 1'-6" x 2'-6" (ht)	1	Nos.		
2	ELECTRICAL FIXTURES AND FANS				

	Supplying and fixing in position, effecting proper connection testing & commissioning of all fixtures and fittings , like exhaust fans, all types of lighting fixtures with lamps, call bells etc fixing of connectors including providing flexible conduits with glands hardware, rawl plugs complete as required.				
(i)	36 watt LED Light Fixture (2'x2') Philips/Wipro/Havelles	21	nos.		
(ii)	18W LED downlighter Spot Lamps. Philips/Wipro/Havells	23	nos.		
(iii)	1x36 watt TL surface mounted luminaire with TL flourscent lamp.Philips/Wipro/Crompton	7	nos.		
(iv)	Philips/Wipro i/c yellow tubes for cove lights	18	nos.		
(v)	2' long tube light fixture for cash cabin	1	nos.		
(vi)	Wall mounted fan with oscillating mechanism 300mm/400mm 3 speed regulator of any make including grouting steel raw plugs on walls / columns complete including wiring from the socket to fan complete.	13	nos.		
(vii)	Supplying & fixing ceiling fan of approved make including providing fan hook etc complete with providing & fixing modular step regulators & including making necessary connections.	2	nos.		
(viii)	Supplying & fixing 225mm dia nominal low noise plastic ventilation fans of approved make including cutting holes and fixing fans as required. Newtek or Usha made with louvers	3	nos.		
(ix)	Supplying & fixing call bell buzzer with indicator & reset facility operating on 230 volts (wiring is counted as light point).	7	nos.		
3	MAIN PANEL BOARD				

3.1	Design , manufacture supply, installation , effecting proper connection, testing & commissioning of 1.62/2.0mm thick sheet steel fabricated surfaces / recessed mounted , main panels complete with Aluminium bus bars, separate neutral links for each phase connectors earth bus phase barriers cover interconnecting copper wires, including epoxy powder coating as per technical specifications as required :-				
	Incomer : 160 Amp TP MCCB - 1no. 0-500V CTs - 3 nos.9Current Transformers) 3 nos. indication lamps with fuses - 1 set 200A 4P copper bus bar - 1 Set				
	Outgoing 125A 4P Change Over Switch 63A 4P MCB - 6nos. 63A DP MCB - 6 nos.	1	set		
3.2	P/F 200 amp MCCB switch near Meter in 16 swg sheet cubicle box of L 7 T DH - 200 25 KA (Near meter) complete with incoming & outgoing connections.	1	Set		
	CABLE FROM METER TO PANEL BOARD				
4	Cables : Supply, laying , fixing in position of the following size PVC insulated aluminium conductor armoured cables as per IS : 1554 i/c fixing the clamps on trays, on supports including end terminations with single compression glands, lugs complete.				
	3.5x50 sq.mm armoured cable.	40	Rmt		
	DISTRIBUTION BOARDS				
5	Distribution boards : Design, manufacture, supply of 1.6mm thick sheet steel fabricated surface/ recessed mounted, vertical configuration , double door type , distribution boards (factory made with powder coating)				
6	<u>DB for AC</u>				
	4 way TPN DB , Incoming: 63 Amp. 4 pole MCB Outgoing :12 nos. SP MCB	1	Set		
7	<u>DB for Light and Power</u>				
	4 way TPN DB , Incoming :40 A 4 pole MCB , Outgoing :12 nos. SP MCB	1	Set		

	EARTHING STATION : (2 for branch & 1 for E-lobby)				
8	FOR EARTHING (With COPPER PLATE) (i) Earthing installation as per I.E. rule conforming to IS 3043-1987 or its latest amendent by making earth station with 600x600x3mm(minimum) thick copper plate electrode to be installed such that is top edge shall be at a minimum depth of 3.3mts below ground level after preparation of ground with charcoal, sand ,& salt, connecting the 25x3mm thick copper strip from ground level to the copper plate by bolting and brazing to the copper plate (Cost of copper strip to be paid seperately) complete with Brass bolt of suitable length double nuts & washer including supply & fixing of 50mm dia 2.3Mts long partly perforated G.I. Pipe with funnel for watering arrangment. N.B :- The Copper plate to be buried under 3.3Mts depth from ground level, including C.I. Pit 300x300mm with necessary brick wall	3	Set		
	(ii) Providing & fixing 25mmx3mm thick copper earth strip from earth spike to copper plate by bolting & brazing to the copper plate complete with brass bolt of suitable length.	18	Rmt		
	(iii) 10 sq.mm insulated Cu earth wire in PVC conduit pipe (from UPS earth bus bar to the ground level of main earth)	45	Rmt		
	TOTAL				

SCHEDULE OF QUANTITIES (SCHEDULE - C)

Sub: Air Conditioning Works in Branch Office & E-Lobby at PRECIOUS MALL, MOTI DOONGRI ROAD Z/O JAIPUR

S.No.	ITEM	QTY	UNIT	RATE (Rs.)	AMOUNT (Rs.)
	HIGH WALL SPLIT UNITS				
1	Supply and installation of High Wall Split Air Conditioners with cordless remote having inbuilt timer with standard Accessories such as drain pipe, copper tube, electrical cable etc. with each AC unit . The rates should include FIVE years comprehensive warranty. The cost include 3 mtr copper refrigerant pipe.				
(a)	Nominal Capacity - <u>1.0 TR</u> (Make - Blue Star,Hitachi , Voltas.(2 in ATM)	3	Nos		
(b)	Nominal Capacity - <u>1.5 TR</u> (Make - Blue Star,Hitachi , Voltas.(in Branch)	4	Nos		
2	Timer to alternate power supply between the AC units in configurable time durations.	1	No.		
	VOTAGE STABLIZER FOR HIGH WALL SPLIT AC				
4	Supply installation testing & comisioning of Voltage Stabilizer of approved make- 4 KVA Note: All voltage stabilizer is sufficient for A.C.should have time delay facility.	7	Nos		
5	Copper Refrigerant Piping :				
	Installation & commissioning of Soft copper piping with complete fitting & insulation including chisling, plastering of walls to conceal copper pipe & electrical wire with plaster finish	33	Rmt		
6	Drain Piping				

	Hard PVC insulated drain water piping work of size 25 mm dia with complete fitting including Chisling, plastering of walls etc complete	50	Rmt		
7	Electrical Cable				
	Providing & fixing of interconnected electrical wiring between indoor & outdoor unit as req.complete as per design & specification of manufacturer.	48	Rmt		
8	Frame Work :Supply fabrication & installation of MS angle iron stand with safety cage for ODU complete with hanger& suporting Arrange-ments as required				
	For High Wall split ACs	7	Nos		
	TOTAL				

- Note: 1.Components of AC should have 5 years warranty
2. Air- Conditioners should be Blue star/Voltas/Hitachi
3.Air- Conditioners should have 3 star rating by BEE.

SCHEDULE OF QUANTITIES (SCHEDULE - D)

(Narender Consultants)

**Sub: Server Room in Indian Bank's Branch at PRECIOUS MALL, MOTI DOONGRI ROAD
Z/O JAIPUR**

S.No.	ITEM	QTY	UNIT	RATE (Rs.)	AMOUNT (Rs.)
I	FURNISHING				
	RUNING COUNTER SERVER COUNTER	5	Rft		
II	ELECTRICAL				
1	(i) Wiring of AC points with 2x6+1x2.5 sq.mm PVC insulated stranded Cu. Conductor wires in ISI marked medium grade PVC conduits above ceiling including cost of conduits, wall chases complete as required including providing metal clad socket with SPMCB in sheet steel enclosure (one point per circuit, circuit shall not be paid extra).	2	nos.		
	(ii) Providing & fixing of Anchor Roma power socket near indoor units for supply to split type ACs	2	nos.		
2	From panel to UPS though input switch (UPS Supply): 4x10 sq.mm + 1x4 sq.mm Cu. Wire	20	rmt		
3	From UPS to UPS DB though output switch: 2x6 sq.mm + 1x2.5 sq.mm Cu wire	5	rmt		
4	DATA SYSTEM - CONDUITING & CABLING				

4.1	Wiring for computer networking from I/O hub to computer workstation with Cat -6 computer cable including providing ferrules at both ends and termination at both ends including providing & fixing frame for with shutter , RJ 45 outlet, faceplate and mounting box complete of modular type, This work includes providing PVC conduits in chases from the I/O hub to the point.	14	nos.		
4.2	Supply of CAT-6 DLink Patch Cord 7 ft	14	Nos.		
4.3	Supply of CAT-6 DLink Patch Cord 3 ft	14	Nos.		
4.4	Supply/Fixing of CAT-6 Jack Panel 24 Port	1	Nos.		
4.5	Supply/Fixing of Networking Box 12 U Size	1	Nos.		
4.6	S/F 24 Port D Link switch	1	No.		
4.7	Testing/Commisioning Charges	1	1 Job		
5	UPS SYSTEM				
5.1	<u>DB for UPS Input</u>				
	63 Amp Dipole MCB	2	nos.		
5.2	<u>UPS Output</u>				
	P/F 40A DP MCB in MS box (for UPS output in UPS Room)	2	nos.		
5.3	<u>UPS DB</u>				
	12 Way SPN Distribution boards with 1 no. 60 A 2 pole MCB isolator, 10 nos. 6/10 SP MCBs (for UPS distribution board)	1	nos.		

5.4	Wiring for UPS power socket with 2x2.5+1x1.5 sq.mm PVC insulated Cu. Conductor wires in ISI marked PVC including providing & fixing switch box, 3 nos. 5 amp sockets, 1 no. 16 amp switch, one indicator modular type with grid and face plates modular type (Maximum three stations per circuit , Circuit shall not be paid extra).	14	nos.		
III	AIR CONDITIONING WORKS				
	HIGH WALL SPLIT UNITS				
1	Supply and installation of High Wall Split Air Conditioners with cordless remote having inbuilt timer with standard Accessories such as drain pipe, copper tube, electrical cable etc. with each AC unit . The rates should include FIVE years comprehensive warranty. The cost include 3 mtr copper refrigerant pipe.				
(a)	Nominal Capacity - <u>1.0 TR</u> (Make - Blue Star, Hitachi , Voltas.(in ATM and server room)	2	Nos		
2	Timer to alternate power supply between the AC units in configurable time durations.	1	No.		
	VOTAGE STABLIZER FOR HIGH WALL SPLIT AC				
3	Supply installation testing & comisioning of Voltage Stabilizer of approved make- 4 KVA Note: All voltage stabilizer is sufficient for A.C. should have time delay facility.	2	Nos		
4	Copper Refrigerant Piping :				
	Installation & commissioning of Soft copper piping with complete fitting & insulation including chisling, plastering of walls to conceal copper pipe & electrical wire with plaster finish	8	Rmt		
5	Drain Piping				
	Hard PVC insulated drain water piping work of size 25 mm dia with complete fitting including Chisling, plastering of walls etc complete	15	Rmt		

6	Electrical Cable				
	Providing & fixing of interconnected electrical wiring between indoor & outdoor unit as req.complete as per design & specification of manufacturer.	18	Rmt		
7	Frame Work :Supply fabrication & installation of MS angle iron stand with safety cage for ODU complete with hanger& suporting Arrange-ments as required				
	For High Wall split A	2	Nos		
	TOTAL				

SCHEDULE OF QUANTITIES (SCHEDULE - E)

(Narender Consultants)

Sub: Furnishing/Electrical works in Indian Bank's E-Lobby at Precious Mall, Moti Doongri Road Z/O JAIPUR

S.No.	ITEM	QTY	UNIT	RATE (Rs.)	AMOUNT (Rs.)
	FURNISHING				
1	P/F armstrong acoustical suspended ceiling system as per drawing with 15mm thick FISSURED tiles having tegular edges complete as per manufacturers specifications.	59	Sq.Ft.		
2	<u>Aluminium Glazed Doors</u>				
2.1	P/F of Powder Coated Aluminium Glazed Doors/ Windows in approved colour with toughened glass as per design	56	Sq.Ft.		
2.2	P/F Floor Spring ISI approved	1	Nos.		
3	MISCELLENEOUS				
3.1	Outer Shutter Box for ATM	35	Sq.Ft		
3.2	Dust Bin (in ATM)	1	No.		
3.3	Visual Merchandising (in ATM): Designer level customised bank branded silver colour information Panel Writing ledge, cheque deposit box, 16sqg cr imported metal, die pressed with powder coat and imported silver duco of ral/ dupont make, pp coating for protection against UV light and for scratch resistance, 50 x 8 csk mirror cap wooden threaded metal screw.	1	Set		
3.4	Vinyl Designer Kit for Glass (in ATM) : Providing and fixing vinyl designer kit for front glass 1/2" thick Ultra blue, full set as per customised design	1	Set		

3.5	Customized Sticker Set (in ATM) : Colour Customized user stickers for ATM input/ output devices, entrance door.	1	Set		
3.6	Stainless Steel Bank Logo (in ATM)	1	No.		
3.7	Poster Frames Wall Hung (in ATM): Sheets of 36" x 24" clear acrylic (poster to be sandwiched in between) Outer sheet in 5 mm th and bevelled crystal edge polished for 3/4" at 8-10 degrees on all sides in the front. Rear sheet is 5mm th flat.Rate inclusive of S1 grade aluminium.	1	No.		
3.8	Singage including Lighting Vinyl Stickers (in ATM): in approved pantone shade. Substrate - Metaflex - Meta II (metamark) Box - GI approved colour powder coated Aluminium extrusions for tensioning - top & bottom covered with 18 SWG AL Size is 8 x 3 sheets, white powder coated with GI back cover. Drop cap to be provided. Electrical fitting : one 36W tube light to be provided for every 4 Sq.Ft. of area.	24	Sq.Ft.		
3.9	Providing 2kg capacity CO2 type fire extinguisher of minimax / Cease fire/ Supreme or equivalent (in ATM)	1	No.		
3.10	Door Pillar (in ATM) : Providing & fixing in position Aluminium Composite Panel Box which will be 12mm marine ply finished with ACP (Colour Silver Grey)	14	Sq.Ft.		
4	WALL PANELLING & PAINTING				
	Providing, fabricating and fixing in position Aluminium Composite Panel in approved colour & shade on outer walls near entrance of e-lobby and inner walls of E-lobby complete.	325	Sq.Ft.		
5	ELECTRICAL				

5.1	(i) Wiring of AC points with 2x6+1x2.5 sq.mm PVC insulated stranded Cu. Conductor wires in ISI marked medium grade PVC conduits above ceiling including cost of conduits, wall chases complete as required including providing metal clad socket with SPMCB in sheet steel enclosure (one point per circuit, circuit shall not be paid extra).	2	nos.		
	(ii) Providing & fixing of Anchor Roma power socket near indoor units for supply to split type ACs	2	nos.		
5.2	4 core - 10mm 2 copper armoured cable of ISI make for ATM	20	Rft.		
5.3	Servo controlled stabilizer for ATM	1	No.		
5.4	P/F 8 way SPN DB for ATM	1	Each		
5.5	P/F Di pole 40 Amp MCB for input of UPS for ATM	1	Each		
5.6	P/F Circuit breaker 100 Amp. (ELCB) ISI make with steel Box for ATM.	1	Each		
	ELECTRICAL FIXTURES AND FANS				
5.7	Supplying and fixing in position, effecting proper connection testing & commissioning of all fixtures and fittings , like exhaust fans, all types of lighting fixtures with lamps, call bells etc fixing of connectors including providing flexible conduits with glands hardware, rawl plugs complete as required.				
(i)	36 watt LED Light Fixture (2'x2') Philips/Wipro/Havells	2	nos.		
(ii)	18 W LED downlighter Spot Lamps.Philips/Wipro/Havells	2	nos.		
	TOTAL				

SCHEDULE OF QUANTITIES (SCHEDULE - F)

(Narender Consultants)

**Sub: Miscellaneous works in Indian Bank's Branch at at Precious Mall, Moti Doongri Z/O
JAIPUR**

S.No.	ITEM	QTY	UNIT	RATE (Rs.)	AMOUNT (Rs.)
1	P/M/F Customer desk complete as per Bank's approved design.	1	no.		
2	P/M/F cheque drop box as per Bank's approved design.	1	no.		
3	P/M/F complaint box as per Bank's approved design.	1	no.		
4	Providing/ fixing of frosted film as per design on glass panes as required.	200	Sq.Ft.		
5	Providing & fixing soft board with necessary framework with 12mm commercial plywood on top jolly board to be fixed finished with fabric @ Rs.80, with necessary mouldings duly polished along the periferi	20	Sft		
6	<u>Façade on Entrance Door</u>				
	Providing/ Fixing of Aluminium Composite panel in approved colour and shade as required (on outer wall near the entrance of branch)	120	Sq.Ft.		
	TOTAL				

SCHEDULE OF QUANTITIES (SCHEDULE - G)

(Narender Consultants)

**Sub: Painting/Wall finishing works in Indian Bank's Branch at Precious Mall, Moti
Doongri Road Z/O JAIPUR**

S.No.	ITEM	QTY	UNIT	RATE (Rs.)	AMOUNT (Rs.)
1	PANELLING P/M.F. full height wooden panelling by mean of 1"x2" frame work for levelling of wall @ 2'-0"c/c both ways & then nailing 2/8" commercial ply with facing of 1mm laminate with nail groove joint as per design.(to be provided in main banking hall, manager cabin, server room of branch & ATM)	745	Sq.Ft.		
	PAINTING /POLISHING/FINISHING				
2	P/A P.O.P. Punning on walls to make them well levelled (to be provided in strong room only)	450	Sft		
3	P/A plastic Emulsion paint of approved shade over primer coat on walls including scraping/ removing of existing paint.(to be provided in strong room, recod room, ups, toilets, pantry and passage outside strong room.	1400	Sft		
4	P/A synthetic enamel paint, in 3 coats on rolling shutter, doors, windows and grills etc i/c a primer coat of red oxide.	225	Sft		
	TOTAL				

CORRIDOR

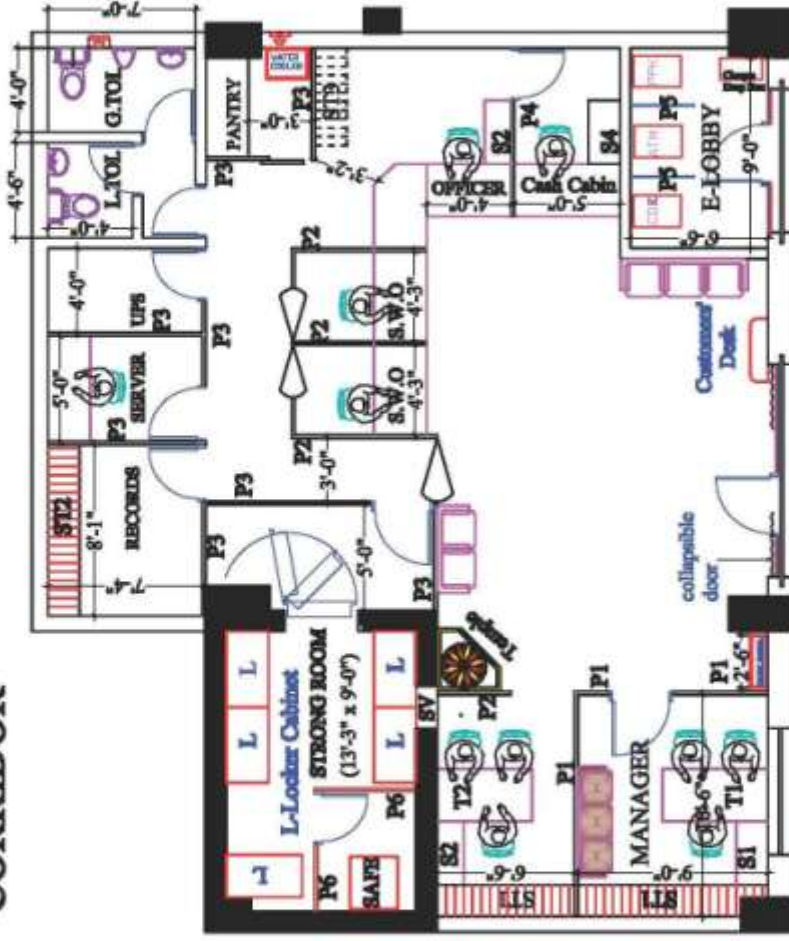

PASSAGE

GROUND FLOOR

ENTRY TO
MAIN BRANCH

ENTRY TO
E-LOBBY

ROAD

DRAWING-4

PROPOSED FURNISHING LAYOUT PLAN OF
INDIAN BANK'S BRANCH AT PRECIOUS
MALL MOTI DOONGRI ROAD FOR INDIAN
BANK, Z/O - JAIPUR

NARENDER CONSULTANTS

ARCHITECT, INTERIOR DESIGNERS &
VALUERS

207, PARKDEAN MARG, BHANDELARI
COLONY, JALDEZI-110009.

TEL - 27659662, MOB- 9810039762

e mail - nrenders@nrenders@yahoo.com

DATED:- 14-12-2016

CORRIDOR

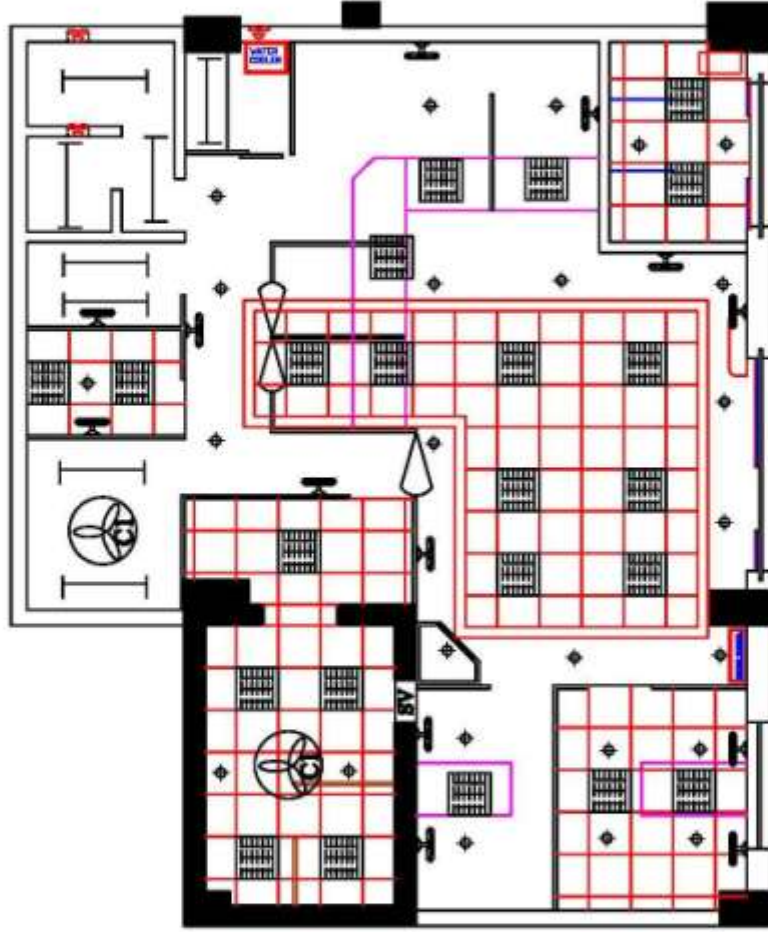

PASSAGE

**ENTRY TO
MAIN BRANCH**

**ENTRY TO
E-LOBBY**

GROUND FLOOR

DRAWING-4

**PROPOSED ELECTRICAL LAYOUT PLAN OF
INDIAN BANK'S BRANCH AT PRECIOUS
MALL MOTI DOONGRI ROAD FOR INDIAN
BANK, Z/O - JAIPUR**

NARENDER CONSULTANTS

**ARCHITECTS, INTERIOR DESIGNERS &
VALUERS**

**207, PARKIAN MARG, BHANDELARI
COLONY, DELHI-110009.**

TEL - 27609662, MOB- 9810039702

e mail - narenderconsultants@yahoo.com

DATED:- 14-12-2016

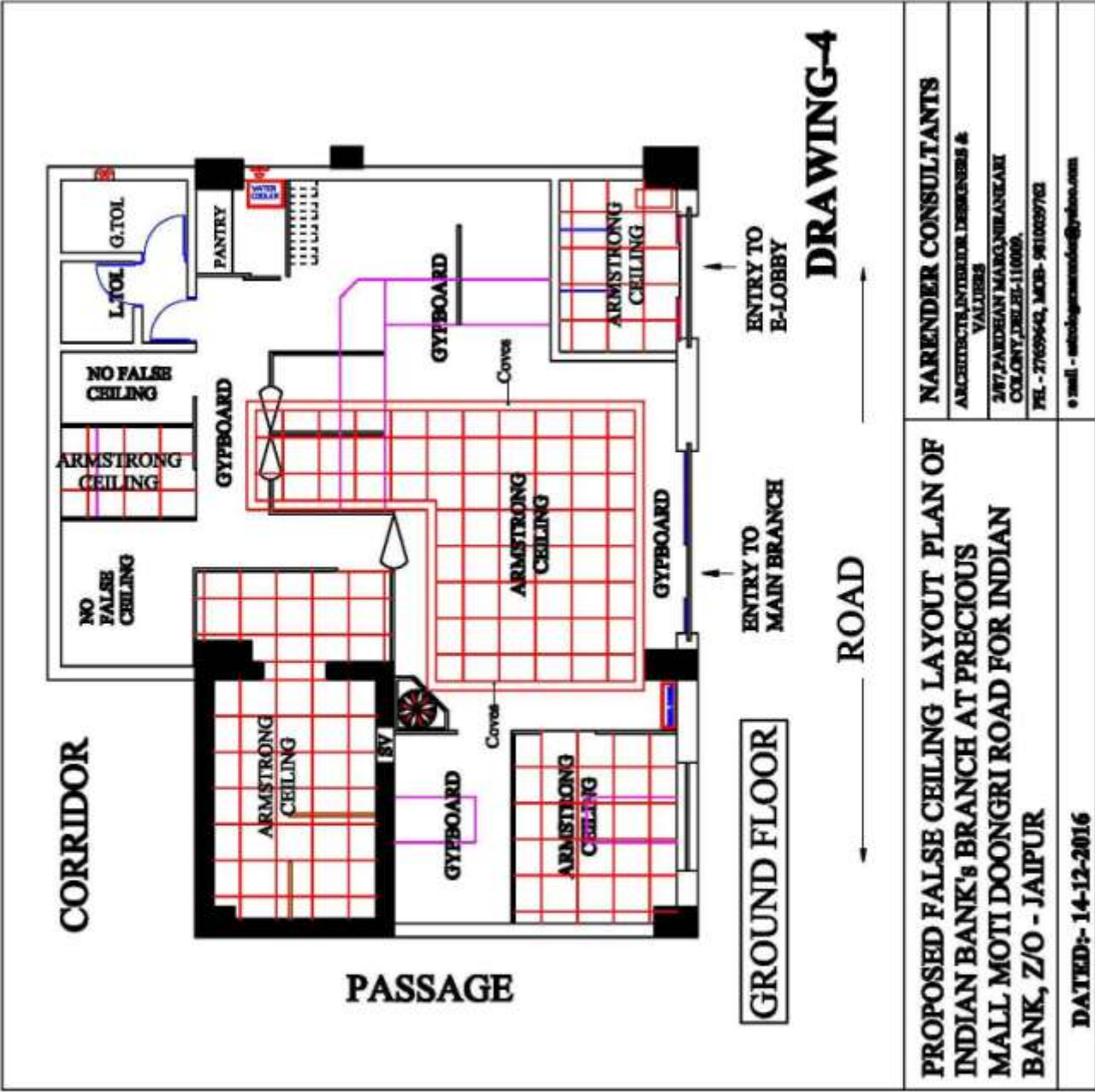

**PROPOSED FALSE CEILING LAYOUT PLAN OF
INDIAN BANK'S BRANCH AT PRECIOUS
MALL MOTI DOONGRI ROAD FOR INDIAN
BANK, Z/O - JAIPUR**

NARENDER CONSULTANTS
ARCHITECTS/INTERIOR DESIGNERS &
VALUERS

287, PARKER MARG, BHANSAI
COLONY, DELHI-110009.

TEL - 27609662, MOB- 9810039762

e mail - narenderconsultants@yahoo.com

DATED:- 14-12-2016

INDIAN BANK

B/O PRECIOUS MALL, MOTI DOONGRI ROAD Z/O JAIPUR

FURNISHING LEGEND

PARTITIONS:-

- P1:- FULL HEIGHT PARTLY GLAZED PARTITION WITH 10mm GLASS (FOR MANAGER CABIN)**
- P2:- LOW HEIGHT SEMI GLAZED PARTITION (4'-0" Ht.) WITH 8mm TOUGHENED GLASS**
- P3:- FULL HEIGHT SOLID PARTITION BOTH SIDE LAMINATED**
- P4:- CASH CABIN PARTITIONS, SOLID BOTH SIDE LAMINATED UP TO CASH COUNTER HEIGHT AND GLASS ABOVE.**
- P5:- 12MM TOUGHENED GLASS PARTITION FOR E-LOBBY**
- P6:- 7'-0" HIGH SOLID PARTITION FOR SAFE IN STRONG ROOM.**

TABLES:-

- T1: 5'-0"x2'-6"x2'-6"**
- T2 :4'-6"x2'-3"x2'-6"**

SIDE RUNNERS :-

- S1- 3'-0"x1'-6"x2'-6"(Ht.)**
- S2- 3'-0"x1'-3"x2'-6"(Ht.)**
- S4 - 3'-0"x1'-3"x2'-6"(Ht.) for cash cabins with 3 drawers**

STORAGE:-

- ST1 - Low height storage (1'-6" deep, 2'-6" ht.) behind tables.**
- ST2 - Full height storage (1'-6" deep, 7 ht)**
- ST3 - Overhead storage at 6' ht (1'6" deep)**

ELECTRICAL LEGEND



36 W LED LIGHT FIXTURES (2'x 2')



1 x 36 Watt Strip type Surface mounted tubelight fixture



18 W LED DOWNLIGHTERS Spot Light Fixtures



WALL FAN



C1 CEILING FAN 48"



EXHAUST FAN

AIR CONDITIONERS LEGEND



- A1 = 1.0 ton HW split A.C**
- A2 = 1.5 ton HW split A.C**
- A3 = 2.0 ton HW split A.C**